

ClassicBeadboard



New England Classic® now offers a beadboard solution that not only looks totally authentic, but out performs today's conventional beadboard alternatives by a country mile.

Featuring a crisp, rounded double bead design, New England Classic® has virtually re-created the look and feel of the "Cottage-Style" architecture at its best.

The system includes panel sections, rails, caps and shoes and is designed to intergrate perfectly with New England Classic® FramePaks® and CasingPaks® so door and window moldings match seamlessly.

All substrates are engineered wood core which insures minimal seasonal expansion and contraction so there are no unsightly gaps or seams.

The installation is literally a snap requiring less than half the time compared with solid boards. Painting is also quick and simple with no sanding necessary.

The cost of the ClassicBeadboard® system will surprise you, and the time saved in installation and finishing makes the system more than affordable for virtually every project.

There is no better way to bring the warmth and style of beadboard to your next project than with the New England Classic® system. Panels are available in primed or stain grade. When combined with the FramePak, the installed system has eight finished heights: 32", 36", 40", 44", 69", 73", 104", and 108".

ClassicBeadboard® Systems

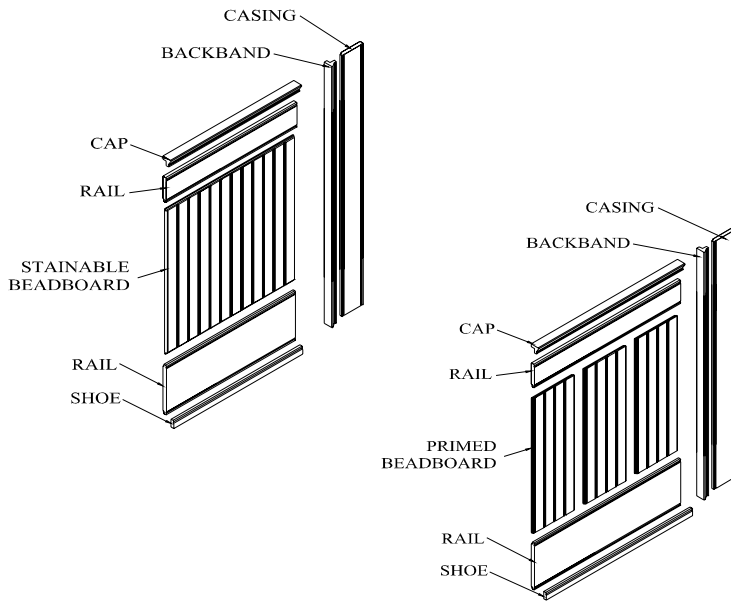

Component Dimensions

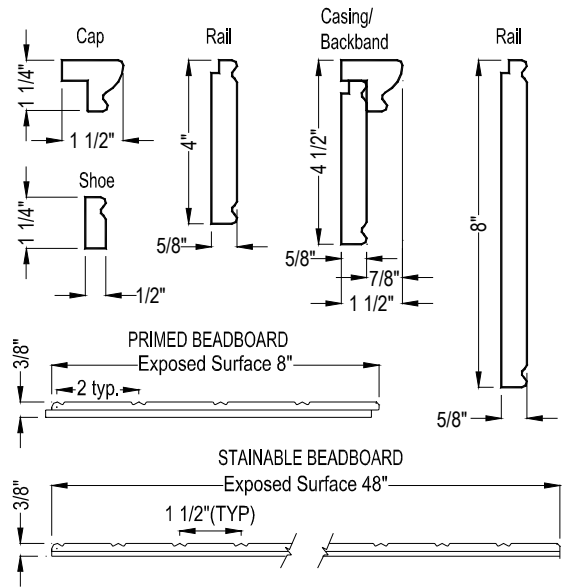

System Height Configurations

	23" PanelSet	31" PanelSet	60" PanelSet	95" PanelSet
32" FramePak	32" Overall	40" Overall	69" Overall	104" Overall
36" FramePak	36" Overall	44" Overall	73" Overall	108" Overall

Components are packaged for convenient ordering, handling and use.

8" Primed Beadboard PanelSet®

Available in 23", 31", 60", and 95" heights.
Each package contains:
6 - Panels (8" wide)

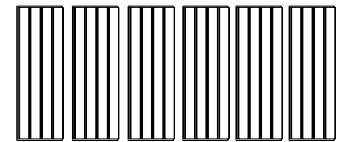

48" Stainable Beadboard PanelSet®

Available in 23", 31", 60", and 95" heights.
Each package contains:
2 - Panels (48" wide)

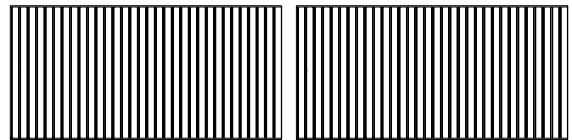

FramePak®

Available with either 4" (32" FramePak®) or 8" (36" FramePak®) base rail.
Each package contains: (96" length)
1 - Cap
1 - Top rail
1 - Bottom rail (4" or 8")
1 - Shoe

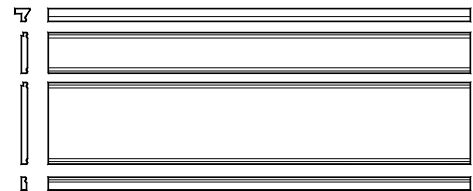

CasingPak®

Window and door trim designed to match. Available in 96" lengths.
Each package contains: (96" length)
3 - Caps
3 - 4" Rails

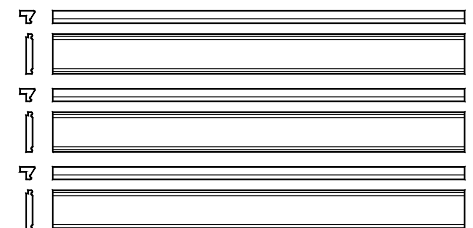

Product Specifications

PART 1.0 GENERAL

1.1 DESCRIPTION

A. ClassicBeadboard® systems shall be the New England Classic® ClassicBeadboard® Systems manufactured by the New England Classic, Inc. Company.

1.2 SUBMITTALS

B. Submit manufacturer's literature and installation instructions to determine layout requirements

1.3 DELIVERY, STORAGE, AND HANDLING

A. Delivery of Product: The ClassicBeadboard panel system shall be delivered to the job site in the manufacturer's original packaging with manufacturer's identification intact and legible.

B. Storage & handling: The ClassicBeadboard panel system shall be stored and handled in such a way to protect against contact with water, exposure to weather, breakage and damage. Do not store directly on concrete without a plastic sheet as a moisture barrier.

1.4 LIMITATIONS

A. Moisture Conditions: the ClassicBeadboard panel system shall not be used in wet or damp areas.

B. Temperature conditions: The ClassicBeadboard panel system shall not be used in contact with surfaces where temperatures exceed 120° F.

PART 2.0 PRODUCTS

2.1 ACCEPTABLE MANUFACTURER

New England Classic®, Inc.
3 Adams Street

2.2 MATERIALS

A. Substrate shall be industrial grade class 1 (fire retardant) or 3, or moisture resistant MDF, product class MD. or EFB Wheatboard (particleboard) product class M3, that conforms with ANSI A208.2-1994.

Panel substrate shall be 5-ply veneer core plywood, bonded with Type II adhesive in accordance to ANSI/HPVA HP-1-1994.

B. Adhesive for bonding veneers to substrate shall be PVA, EVA, or PUR type adhesive.

C. Real wood veneer shall be grade-A, sanded to 180 grit.

D. Factory finish shall be either lacquer or conversion varnish per Architectural Woodwork Institute (AWI) Custom Grade Specifications: TR-2 and OP-2 for lacquer, and TR-4 and OP-4 for conversion varnish finish.

2.3 COMPONENTS

A. 8" Primed Beadboard Panel

$8\frac{5}{32}$ "x $23\frac{1}{2}$ "x $\frac{3}{8}$ "thick
 $8\frac{5}{32}$ "x $31\frac{1}{2}$ "x $\frac{3}{8}$ "thick
 $8\frac{5}{32}$ "x $60\frac{1}{2}$ "x $\frac{3}{8}$ "thick
 $8\frac{5}{32}$ "x $95\frac{1}{2}$ "x $\frac{3}{8}$ "thick

B. 48" Stainable Beadboard Panel

48"x $23\frac{1}{2}$ "x $\frac{3}{8}$ "thick
48"x $31\frac{1}{2}$ "x $\frac{3}{8}$ "thick
48"x $60\frac{1}{2}$ "x $\frac{3}{8}$ "thick
48"x $95\frac{1}{2}$ "x $\frac{3}{8}$ "thick

C. Cap:

$1\frac{1}{2}$ " x $1\frac{1}{4}$ " x 96" long

D. Rail(s):

$\frac{5}{8}$ " x 4" x 96" long
 $\frac{5}{8}$ " x 8" x 96" long

E. Shoe:

$\frac{1}{2}$ " x $1\frac{1}{4}$ " x 96" long

F. Plate shelf:

1" x $3\frac{1}{2}$ " x 96" long

G. Edge Molding:

$\frac{3}{4}$ " x 3" x 96" long

PART 4.0 FINISHING & MAINTENANCE

4.1 UNFINISHED

OAK, MAPLE, CHERRY

A. Fill all nail holes and splices with matching wood filler. Sand wood filler patches smooth to the veneer surface with 180 grit paper, taking care not to sand through the veneer. Apply stain, sealer and clear finish coat, lightly sanding between coats with 220 grit paper. We recommend applying a light coat of lemon oil or furniture oil to replenish the natural sheen, especially in dry environments.

4.2 FINISHED

A. Use matching color putty to fill fastener holes. A matching stain kit is included with factory finished product.

4.3 PRIMED

A. It is not necessary to prime stiles, rails, shoe, cap, or casing (or factory-primed panels). After installation, apply one coat of paint to panels, then sand with 220 grit paper. DO NOT SAND STILES, RAILS, SHOE, CAP, OR CASING. Fill in nail holes with a paintable vinyl-based spackle. Finish coat all parts together. Gentle household cleaners may be used, if required.

PART 3.0 INSTALLATION

3.1 INSTALLATION

A. Install product per the manufacturer's installation recommendations using the instructions provided.

3.2 WARRANTY

A. Manufacturer shall furnish a five year warranty against defects in material and workmanship.

3.3 MATERIALS

ACCEPCANCE

A. City of New York
MEA 190-99-M



New England Classic, Inc
3 Adams Street
South Portland, Maine 04106
(888) 460-6324
Fax (207) 799-6073
NewEnglandClassic.com

What better walls are wearing